

---

---

# Reactions

---

---

## INTRODUCTION

There are millions of different chemical reactions taking place in our world. Many of them fall into categories that display similar chemical processes. Three common processes are:

1. Precipitation reactions: Two soluble ionic compounds react to form an insoluble compound.

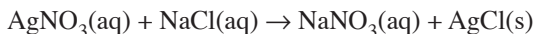

2. Acid-Base reactions: The  $\text{H}^+$  from an acid reacts with the  $\text{OH}^-$  from a base to form water, while the remaining cation and anion form a salt.

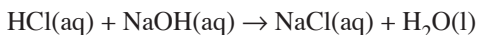

3. Redox reactions: Electrons are transferred from one substance to another.

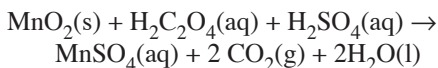

There are some sub-groups of redox reactions involving elements that are time honored reaction types:

- A. Combination reactions: Two elements combine to form one product.

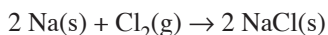

- B. Decomposition reactions: One substance breaks down into two or more elements.

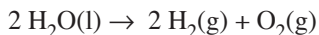

- C. Single replacement reactions: One element in a compound is replaced with another.

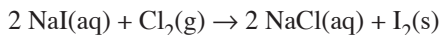
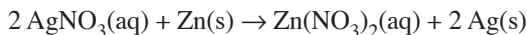

- D. Combustion reactions: An element or compound reacts with oxygen to produce heat and light. A few other substances besides oxygen can also be found in combustion reactions.

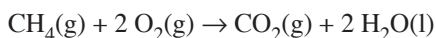

There are also combination and decomposition reactions that involve compounds, rather than elements. These are often not redox reactions.

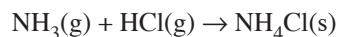

In today's experiment, you will run a series of reactions on a piece of copper wire that will turn it from a wire into a pile of copper powder. Some of the steps are quite interesting to observe. You will be asked to classify the reactions taking place into one or another of the categories described in the introduction to the experiment.

In a greatly simplified diagram, the reactions you will run can be summarized as follows:

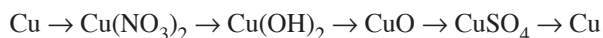

Detailed reactions for each step are as follows:

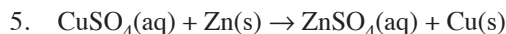
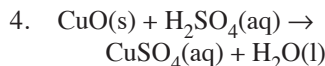
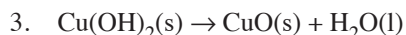
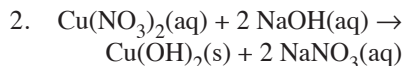
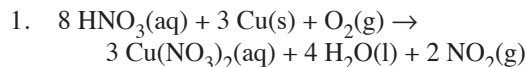

The steps of the experiment are numbered according to the above reactions. The data table asks that you assign to each reaction one of the types from this page. When you classify each reaction, you might find it helpful to do so on this page, and then transfer your answers to the data table. If the reaction falls into one of the sub-groups listed, use that name in your classification.

***Be mindful of safety throughout the experiment. Caustic reagents will be used.***

## EQUIPMENT

### from your locker:

- 1-150 ml beaker
- 1-100 ml beaker
- 1 stirring rod
- 1-25 ml and 1-10 ml graduated cylinder
- 1 evaporating dish

### from the large drawer:

- 1 ring stand
- 2 rings (greater diameter than 150 ml beaker)
- 1 wire gauze
- 1 beaker tongs
- 1 Bunsen burner.

### Special supplies:

- 1 copper wire (It will weigh about 0.25g)

### next to balances:

- Zinc metal

### from the fume hoods (get as needed)

- concentrated  $\text{HNO}_3$ ..... CAUTION
- 3 M NaOH..... CAUTION
- 6 M  $\text{H}_2\text{SO}_4$ ..... CAUTION
- methanol

## EXPERIMENT

**Part 1.** Obtain a piece of pre-cut copper wire and weigh it to the nearest milligram. Record the mass. Bend it in half. Place it in the 150 ml beaker. Use a pencil to write your initials on the white area of the beaker. Erase any old marks. Take the beaker to the fume hood. Use the transfer pipet in the concentrated nitric acid bottle to transfer 2 ml of acid into the beaker. Set the beaker down as the  $\text{NO}_2$  evolves. Swirl the beaker occasionally. Record what you observe in the data table. If it appears that some of the copper has not dissolved, and gas evolution has ceased, warm the beaker on the hotplate until gas begins to evolve once more. When the copper is all dissolved, add deionized water until the beaker is half full. Use the 100 ml beaker to carry deionized water to the fume hood. After the water is added, you may take the beaker back to your work area for the rest of the experiment.

**Part 2.** Obtain 15 ml of 3 M NaOH solution in a 25 ml graduated cylinder. Pour this into the beaker containing the copper solution while stirring constantly. Record your observations. Rinse the graduated cylinder with tap water, then with deionized water, and allow it to drain.

**Part 3.** Set up an apparatus as shown above in the next column. Refer to the bunsen burner handout. Use a hot flame.

Stir gently and constantly to prevent “bumping” (a phenomenon caused by local overheating in thick solutions or solutions containing solids).

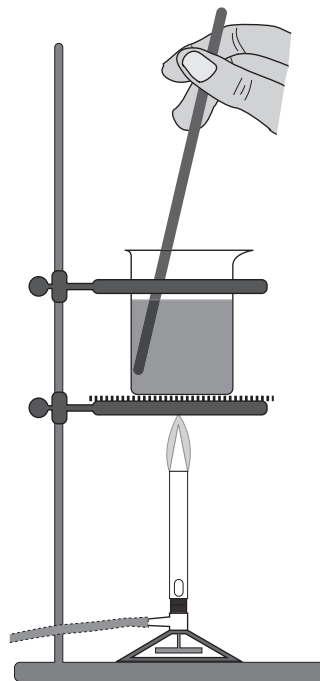

Heat the solution until the blue color is entirely converted to black. This will occur before the solution boils. Turn off the burner, but continue stirring for a short period of time until the heat has evened out. Allow the solid to settle. Use beaker tongs to hold the beaker while you carefully pour off as much liquid from the solid as you can without losing any solid. This is called *decanting*. Pour the liquid into the sink. When you grasp the beaker with the tongs, have the spout of the beaker facing in the direction in which you would point it if you were holding the beaker in your hand. This avoids awkward turning of your wrist to the outside or dipping your whole arm down to pour towards the front. Take your beaker to the hot plate holding the large flask containing hot deionized water. Use the hot pads to pour water into the beaker to somewhere near the 125 ml mark on the beaker. Ask for help if the flask seems too heavy. This rinses side products of the reaction off of the  $\text{CuO}$ . Allow to settle, and then decant. Record your observations.

**Part 4.** Use a 10 ml graduated cylinder to measure 7 ml of 6 M  $\text{H}_2\text{SO}_4$  solution. Add this to the beaker while stirring. Record your observations.

### Part 5.

a) Place a piece of weighing paper on a decigram balance, tare it out, and use your scoopula to add about 1.0 g of fine mesh zinc metal.

b) Working in the fume hood, add the zinc to the beaker. Stir briskly until there are no more bubbles forming and the liquid is colorless. Decant the liquid into the waste container marked “Zinc Waste.”

c) Use a grease pencil to write your initials on an evaporating dish. Transfer the copper to the evaporating dish using a rubber policeman. Add about 5 ml of deionized water. Stir, allow to settle, then decant the water into the sink. Repeat this two more times. Now add 5 ml of methanol, stir, allow to settle, and pour the methanol into the waste container marked "Methanol Waste." Pour off as much as possible.

d) Set the evaporating dish under an infrared heater, or, if there is no room there, on a hotplate set to low. Allow the methanol to evaporate off.

e) Check to see if the copper is dry. Poke it with a stirring rod to see if it seems dry. Do not heat it too long or the copper will oxidize.

f) weigh the copper on the milligram balance. Use weighing paper. Make sure you zero out the mass of the weighing paper.

Record the mass of the copper to the nearest milligram.

g) Spread the copper out on the weighing paper, and after you have finished with the observations table, weigh it again on another piece of creased\* weighing paper to see if the mass remained constant. If it has not, this means that the copper is still wet. There is not enough time in this lab to bring the copper "to constant weight", a technique commonly used to ensure that a sample is dry. Drying and weighing is repeated until the mass remains constant.

h) Use the smaller mass of copper in the calculations required in the experiment.

i) Place the copper in the container provided, label it, and show it to the instructor. You may take it home as a trophy.

\* Creasing the weighing paper before placing the copper on it helps the copper pour smoothly off of the paper.

DATA TABLE		
Original mass of copper wire	g	second weighing
Recovered mass of copper powder	g	g
% recovered from original mass: $\frac{\text{Recovered mass}}{\text{Original mass}} \times 100$	%	

Observations	Rewrite Equation from Page 35; Give Reaction Type
Part 1	
Part 2	
Part 3	
Part 4	
Part 5	

**QUESTIONS**

1. In part 5, after the zinc is added, not only does copper metal appear, as is shown in the chemical equation given, but bubbles also appear. This is due to a single replacement reaction between Zn(s) and H<sub>2</sub>SO<sub>4</sub>(aq). Write out this balanced equation.
2. Zinc also reacts with HCl(aq). Write out this balanced equation.
3. If the % recovered is a number larger than 100%, what accounts for the extra mass of copper in the measurement?
4. Reaction 4 is a variation of an acid-base reaction. Protons are transferred from an acid to the oxygen on CuO. Another common variation occurs when protons are transferred to a carbonate ion. Carbon dioxide and water form. Complete the following reaction:

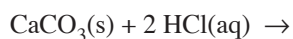

5. Acid-base reactions are also called neutralization reactions. Write out and balance the neutralization reaction between NaOH and H<sub>2</sub>SO<sub>4</sub>. Also show the neutralization reaction between Ca(OH)<sub>2</sub> and HNO<sub>3</sub>.